

ZX1

A CMOS Laser Sensor That's Optimum for Simple Measurements

- A resolution of 0.002 mm that's suitable for simple measurements.
- Stable measurements for any type of workpiece.
- Models available with four different distance specifications.
- Long-distance model for up to 1,000 mm.







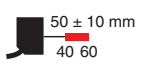

 Refer to **Safety Precautions** on page 6.

This datasheet contains information only for selecting the appropriate model. Be sure to read the instruction sheet for usage precautions prior to using the product.

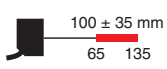

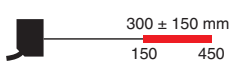
Ordering Information

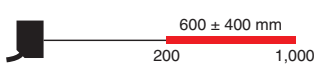
Sensors (Refer to Dimensions on page 5.)

Appearance	Connection method	Cable length	Sensing distance	Model	
				NPN output	PNP output
	Pre-wired	2 m		ZX1-LD50A61 2M	ZX1-LD50A81 2M
		5 m		ZX1-LD50A61 5M	ZX1-LD50A81 5M
	Pre-wired connector	0.5 m		ZX1-LD50A66 0.5M	ZX1-LD50A86 0.5M
	Pre-wired	2 m		ZX1-LD100A61 2M	ZX1-LD100A81 2M
		5 m		ZX1-LD100A61 5M	ZX1-LD100A81 5M
	Pre-wired connector	0.5 m		ZX1-LD100A66 0.5M	ZX1-LD100A86 0.5M
	Pre-wired	2 m		ZX1-LD300A61 2M	ZX1-LD300A81 2M
		5 m		ZX1-LD300A61 5M	ZX1-LD300A81 5M
	Pre-wired connector	0.5 m		ZX1-LD300A66 0.5M	ZX1-LD300A86 0.5M
Pre-wired	2 m		ZX1-LD600A61 2M	ZX1-LD600A81 2M	
	5 m		ZX1-LD600A61 5M	ZX1-LD600A81 5M	
Pre-wired connector	0.5 m		ZX1-LD600A66 0.5M	ZX1-LD600A86 0.5M	

Accessories (sold separately)

Extension Cables for Pre-wired Connector Models An Extension Cable is not provided with the Sensor. Order an Extension Cable separately. (Refer to Dimensions on page 6.)

Cable length	Model
10 m	ZX0-XC10R
20 m	ZX0-XC20R

ZX1

Ratings and Specifications

Item	Model	NPN output	ZX1-LD50A61 ZX1-LD50A66	ZX1-LD100A61 ZX1-LD100A66	ZX1-LD300A61 ZX1-LD300A66	ZX1-LD600A61 ZX1-LD600A66
		PNP output	ZX1-LD50A81 ZX1-LD50A86	ZX1-LD100A81 ZX1-LD100A86	ZX1-LD300A81 ZX1-LD300A86	ZX1-LD600A81 ZX1-LD600A86
Measurement range			50 ± 10 mm	100 ± 35 mm	300 ± 150 mm	600 ± 400 mm
Light source (wave length)		Visible-light semiconductor laser (wavelength: 660 nm, 1 mW max., IEC/EN Class 2, FDA Class II *1)				
Spot diameter (typical) (Defined at the measurement center distance) *2			0.17 mm dia.	0.33 mm dia.	0.52 mm dia.	0.56 mm dia.
Power supply voltage		10 to 30 VDC, including 10% ripple (p-p)				
Current consumption		250 mA max. (at power supply voltage 10 VDC)				
Control output		Load power supply voltage: 30 VDC max., Load current: 100 mA max. (Residual voltage: 1 V max. (load current 10 mA or less), 2 V max. (load current of 10 to 100 mA))				
Analog output		Current output: 4 to 20 mA, maximum load resistance: 300 Ω				
Indicators		Digital display (red), output indicator (OUT1, OUT2) (orange), zero reset indicator (orange), menu indicator (orange), laser ON indicator (green), and smart tuning indicator (blue)				
Response time	Judgment output	Super-high-speed (SHS) Mode: 1 ms High-speed (HS) Mode: 10 ms Standard (Std) Mode : 100 ms				
	Laser OFF input	200 ms max.				
	Zero reset input	200 ms max.				
Temperature characteristic *3			0.03% F.S./°C			0.04% F.S./°C
Linearity *4			±0.15% F.S.		±0.25% F.S.	±0.25% F.S. (200 to 600 mm) ±0.5% F.S. (entire range)
Resolution *5			2 μm	7 μm	30 μm	80 μm
Ambient illumination			Illumination on received light surface: 7,500 lx or less (incandescent light)		Illumination on received light surface: 5,000 lx or less (incandescent light)	
Ambient temperature		Operating: -10 to +55°C, Storage: -15 to +70°C (with no icing or condensation)				
Ambient humidity		Operating and storage: 35% to 85% (with no condensation)				
Dielectric strength		1,000 VAC, 50/60 Hz, 1 minute				
Vibration resistance (destruction)		10 to 55 Hz, 1.5-mm double amplitude, 2 hours each in X, Y, and Z directions				
Shock resistance (destruction)		500 m/s ² 3 times each in X, Y, and Z directions				
Degree of protection *6		IEC 60529, IP67				
Connection method		Pre-wired model (Standard cable length: 2 m, 5 m) Pre-wired connector model (Standard cable length: 0.5 m)				
Weight (packed state/ sensor only)	Pre-wired models (2 m)	Approx. 240 g / Approx. 180 g			Approx. 270 g / Approx. 210 g	
	Pre-wired models (5 m)	Approx. 450 g / Approx. 330 g			Approx. 480 g / Approx. 360 g	
	Pre-wired connector models (0.5 m)	Approx. 170 g / Approx. 110 g			Approx. 200 g / Approx. 140 g	
Materials		Case and cover: PBT (polybutylene terephthalate), Optical window: Glass, Cable: PVC, Mounting hole part: SUS303				
Accessories		Instruction sheet and Laser warning label (English)				

Note: False detection outside the measurement range can occur in the case of an object with high reflectance.

*1. Classified as Class 2 by EN60825-1 criteria in accordance with the FDA standard provisions of Laser Notice No. 50. Notification to CDRH planned. (Center for Devices and Radiological Health)

*2. Spot diameter: Defined as 1/e² (13.5%) of the central intensity at the measurement center distance.
False detections can occur in the case there is light leakage outside the defined region and the surroundings of the target object have a high reflectance in comparison to the target object.

Accurate measurements may not be possible for workpieces that are smaller than the spot diameter.

*3. Temperature characteristic: Value for the case the space between the sensor and Omron's standard target object is secured by an aluminum jig. (Measured at the measurement center distance)

*4. Linearity: Indicates the error with respect to the ideal straight line of the displacement output in the case of measuring Omron's standard target object (white ceramic) at a temperature of 25 °C.

Linearity and measured value may vary depending on target object.

*5. Resolution: Defined in Standard Mode for Omron's standard target object (white ceramic) after executing Smart Tuning.

The resolution indicates the repetition accuracy for a still workpiece. Not an indication of the distance accuracy.

Resolution performance may not be satisfied in a strong electromagnetic field.

*6. IP67 protection applies to the connector on pre-wired connector models if an extension cable is connected.

Engineering Data (Typical)

Linearity Characteristic for Different Materials

ZX1-LD50

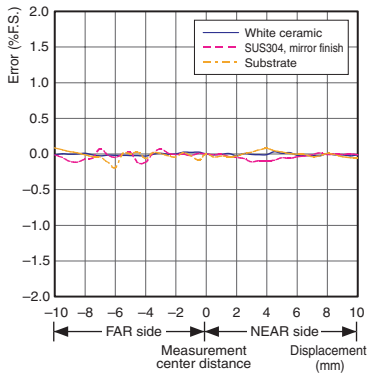

ZX1-LD100

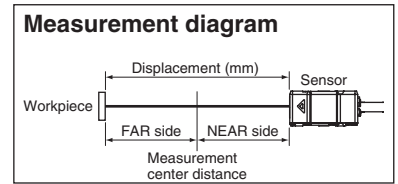
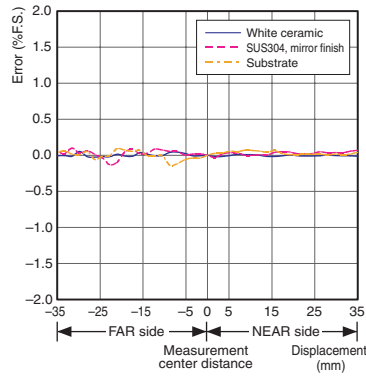

ZX1-LD300

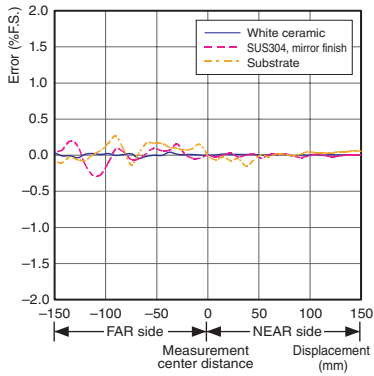

ZX1-LD600

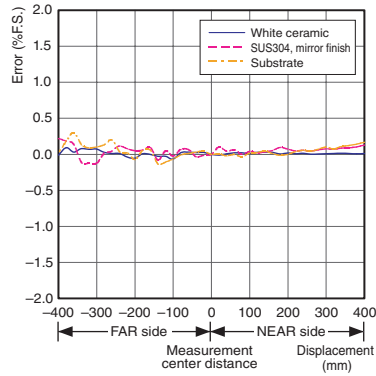

- Note:**
1. Measurement conditions: Standard Mode at a temperature of 25 °C when executing Smart Tuning.
 2. The X-axis displacement indicates the measurement distance displayed on a digital display. The measurement distance displayed on a digital display takes the measurement center distance as 0 and displays the near side of the Sensor as positive and the far side as negative.

ZX1

I/O Circuit Diagrams

NPN Output Model (Negative Common)

ZX1-LD50A61/ZX1-LD50A66
 ZX1-LD100A61/ZX1-LD100A66
 ZX1-LD300A61/ZX1-LD300A66
 ZX1-LD600A61/ZX1-LD600A66

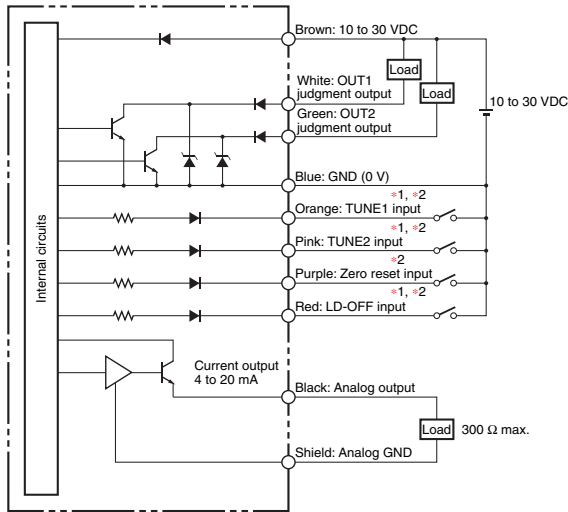

PNP Output Model (Positive Common)

ZX1-LD50A81/ZX1-LD50A86
 ZX1-LD100A81/ZX1-LD100A86
 ZX1-LD300A81/ZX1-LD300A86
 ZX1-LD600A81/ZX1-LD600A86

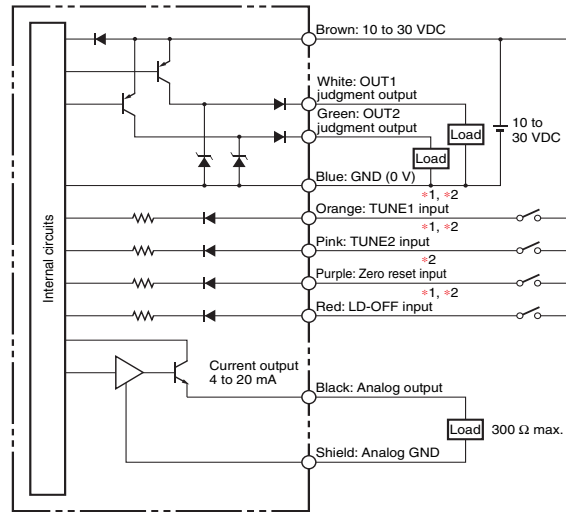

- *1. TUNE1 input: tuning external input for channel 1
 TUNE2 input: tuning external input for channel 2
 LD-OFF input: Laser OFF input
- *2. The input specification is as follows:

	NPN Output Model	PNP Output Model
ON	Short-circuited with 0-V terminal or 1.5 V max.	Supply voltage short-circuited or supply voltage within -1.5 V
OFF	Open (leakage current: 0.1 mA max.)	Open (leakage current: 0.1 mA max.)

Timing Charts

TUNE1 Input / TUNE2 Input

(1) Time identification tuning type

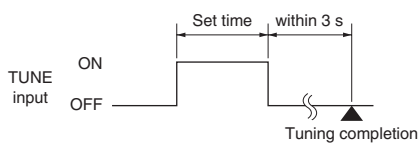

(2) Tuning type other than time identification

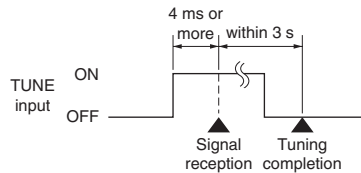

Zero Reset Input

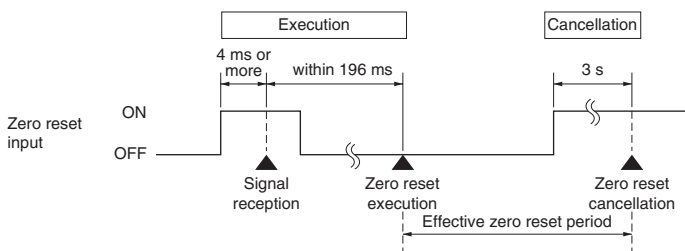

LD-OFF Input

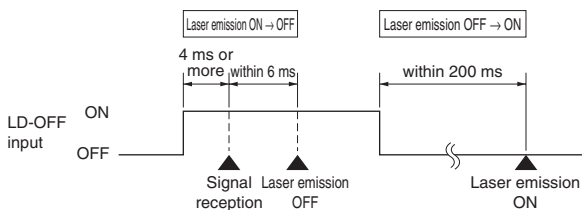

Dimensions

Sensors

Pre-wired Models

ZX1-LD50A□1
ZX1-LD100A□1

Pre-wired Connector Models

ZX1-LD50A□6
ZX1-LD100A□6

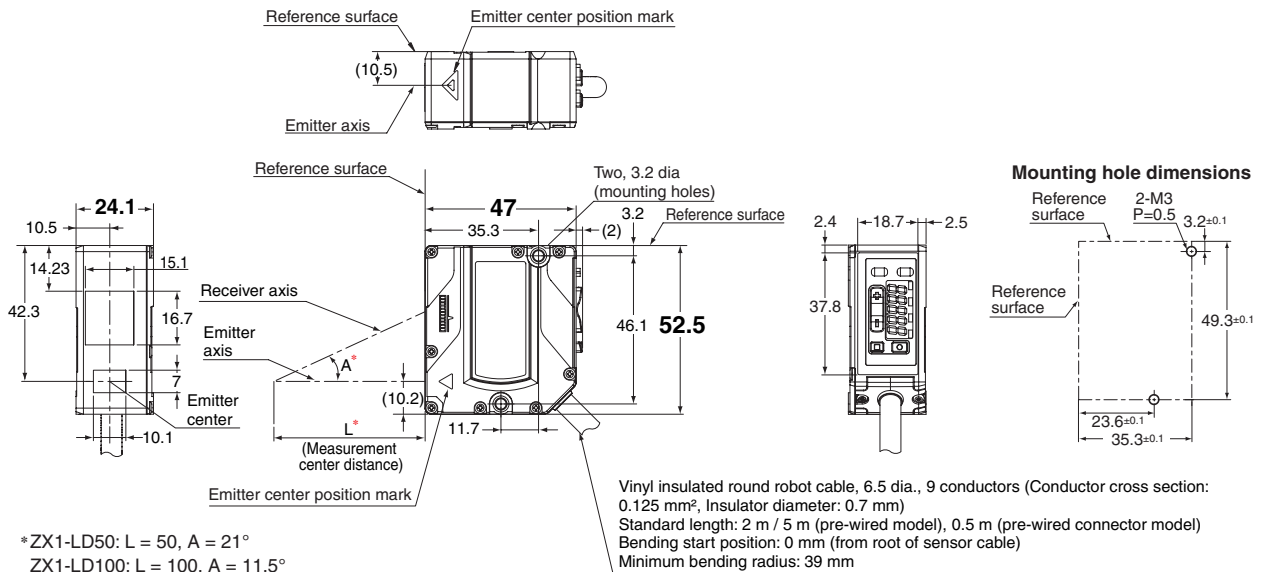

Pre-wired Models

ZX1-LD300A□1
ZX1-LD600A□1

Pre-wired Connector Models

ZX1-LD300A□6
ZX1-LD600A□6

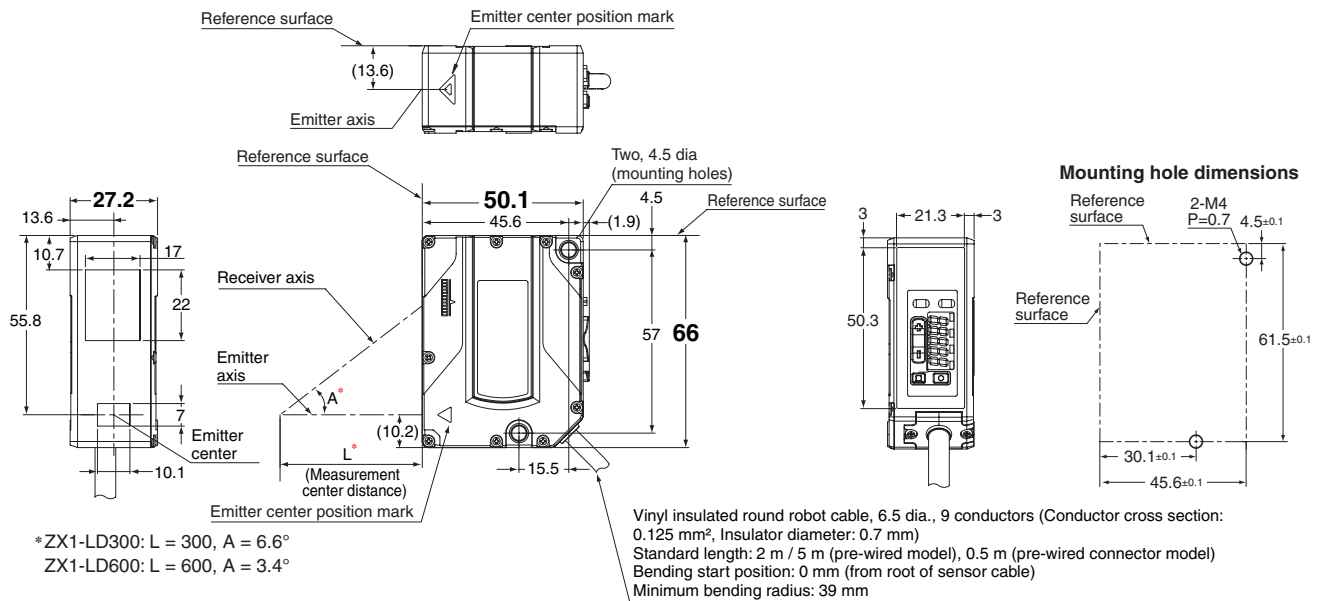

Display, Indicators, and Controls

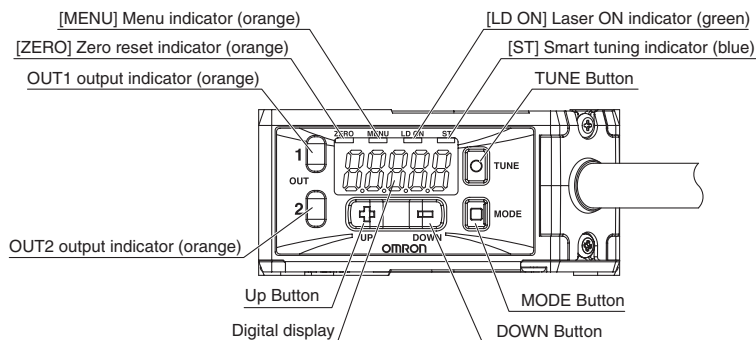

Pre-wired connector

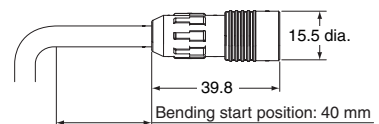

Accessories (sold separately)

Extension Cables for Pre-wired Connector Models

ZX0-XC10R (10 m)

ZX0-XC20R (20 m)

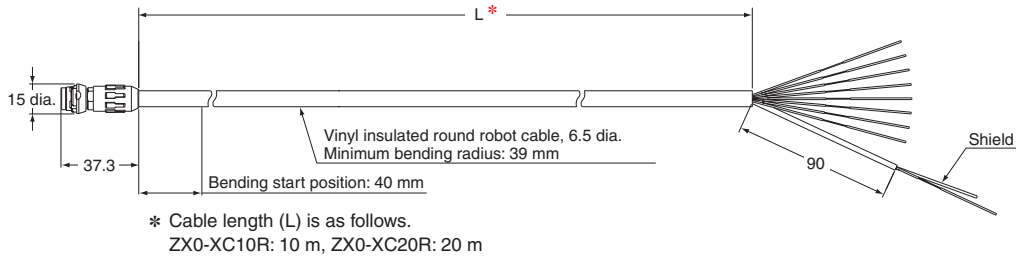

Safety Precautions

This datasheet contains information only for selecting the appropriate model.
Be sure to read the Instruction Sheet for usage precautions prior to using the product.

Laser Safety

⚠ WARNING

ZX1-LD□□□: Class 2

Do not expose your eyes to the laser radiation either directly or indirectly (i.e., after reflection from a mirror or shiny surface).



The laser radiation has a high power density and exposure may result in loss of sight.

Do not disassemble the product.

Doing so may cause the laser beam to leak, resulting in the danger of visual impairment.



- Laser label indications
ZX1-LD□□□ sensors have the following WARNING label on the side.



Using in a country other than the U.S.

- For countries other than Japan and the U.S., warning labels must be replaced by English ones (supplied with the product).

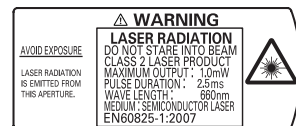

EN60825-1 is provided for products used in Europe, and the content of this standard differs.

- ZX1-LD□□□ is classified as Class 2 device as stipulated in EN60825-1:2007.

Note: For Precautions for safe use and Precautions for correct use, refer to the Instruction Sheet supplied with the product.

READ AND UNDERSTAND THIS DOCUMENT

Please read and understand this document before using the products. Please consult your OMRON representative if you have any questions or comments.

WARRANTY

OMRON's exclusive warranty is that the products are free from defects in materials and workmanship for a period of one year (or other period if specified) from date of sale by OMRON.

OMRON MAKES NO WARRANTY OR REPRESENTATION, EXPRESS OR IMPLIED, REGARDING NON-INFRINGEMENT, MERCHANTABILITY, OR FITNESS FOR PARTICULAR PURPOSE OF THE PRODUCTS. ANY BUYER OR USER ACKNOWLEDGES THAT THE BUYER OR USER ALONE HAS DETERMINED THAT THE PRODUCTS WILL SUITABLY MEET THE REQUIREMENTS OF THEIR INTENDED USE. OMRON DISCLAIMS ALL OTHER WARRANTIES, EXPRESS OR IMPLIED.

LIMITATIONS OF LIABILITY

OMRON SHALL NOT BE RESPONSIBLE FOR SPECIAL, INDIRECT, OR CONSEQUENTIAL DAMAGES, LOSS OF PROFITS OR COMMERCIAL LOSS IN ANY WAY CONNECTED WITH THE PRODUCTS, WHETHER SUCH CLAIM IS BASED ON CONTRACT, WARRANTY, NEGLIGENCE, OR STRICT LIABILITY.

In no event shall responsibility of OMRON for any act exceed the individual price of the product on which liability is asserted.

IN NO EVENT SHALL OMRON BE RESPONSIBLE FOR WARRANTY, REPAIR, OR OTHER CLAIMS REGARDING THE PRODUCTS UNLESS OMRON'S ANALYSIS CONFIRMS THAT THE PRODUCTS WERE PROPERLY HANDLED, STORED, INSTALLED, AND MAINTAINED AND NOT SUBJECT TO CONTAMINATION, ABUSE, MISUSE, OR INAPPROPRIATE MODIFICATION OR REPAIR.

SUITABILITY FOR USE

THE PRODUCTS CONTAINED IN THIS DOCUMENT ARE NOT SAFETY RATED. THEY ARE NOT DESIGNED OR RATED FOR ENSURING SAFETY OF PERSONS, AND SHOULD NOT BE RELIED UPON AS A SAFETY COMPONENT OR PROTECTIVE DEVICE FOR SUCH PURPOSES. Please refer to separate catalogs for OMRON's safety rated products.

OMRON shall not be responsible for conformity with any standards, codes, or regulations that apply to the combination of products in the customer's application or use of the product.

At the customer's request, OMRON will provide applicable third party certification documents identifying ratings and limitations of use that apply to the products. This information by itself is not sufficient for a complete determination of the suitability of the products in combination with the end product, machine, system, or other application or use.

The following are some examples of applications for which particular attention must be given. This is not intended to be an exhaustive list of all possible uses of the products, nor is it intended to imply that the uses listed may be suitable for the products:

- Outdoor use, uses involving potential chemical contamination or electrical interference, or conditions or uses not described in this document.
- Nuclear energy control systems, combustion systems, railroad systems, aviation systems, medical equipment, amusement machines, vehicles, safety equipment, and installations subject to separate industry or government regulations.
- Systems, machines, and equipment that could present a risk to life or property.

Please know and observe all prohibitions of use applicable to the products.

NEVER USE THE PRODUCTS FOR AN APPLICATION INVOLVING SERIOUS RISK TO LIFE OR PROPERTY WITHOUT ENSURING THAT THE SYSTEM AS A WHOLE HAS BEEN DESIGNED TO ADDRESS THE RISKS, AND THAT THE OMRON PRODUCT IS PROPERLY RATED AND INSTALLED FOR THE INTENDED USE WITHIN THE OVERALL EQUIPMENT OR SYSTEM.

PERFORMANCE DATA

Performance data given in this document is provided as a guide for the user in determining suitability and does not constitute a warranty. It may represent the result of OMRON's test conditions, and the users must correlate it to actual application requirements. Actual performance is subject to the OMRON Warranty and Limitations of Liability.

CHANGE IN SPECIFICATIONS

Product specifications and accessories may be changed at any time based on improvements and other reasons.

It is our practice to change model numbers when published ratings or features are changed, or when significant construction changes are made. However, some specifications of the product may be changed without any notice. When in doubt, special model numbers may be assigned to fix or establish key specifications for your application on your request. Please consult with your OMRON representative at any time to confirm actual specifications of purchased products.

DIMENSIONS AND WEIGHTS

Dimensions and weights are nominal and are not to be used for manufacturing purposes, even when tolerances are shown.

ERRORS AND OMISSIONS

The information in this document has been carefully checked and is believed to be accurate; however, no responsibility is assumed for clerical, typographical, or proofreading errors, or omissions.

PROGRAMMABLE PRODUCTS

OMRON shall not be responsible for the user's programming of a programmable product, or any consequence thereof.

COPYRIGHT AND COPY PERMISSION

This document shall not be copied for sales or promotions without permission.

This document is protected by copyright and is intended solely for use in conjunction with the product. Please notify us before copying or reproducing this document in any manner, for any other purpose. If copying or transmitting this document to another, please copy or transmit it in its entirety.

ALL DIMENSIONS SHOWN ARE IN MILLIMETERS.
To convert millimeters into inches, multiply by 0.03937. To convert grams into ounces, multiply by 0.03527.

OMRON Corporation Industrial Automation Company
Tokyo, JAPAN

Contact: www.ia.omron.com

Regional Headquarters

OMRON EUROPE B.V.
Sensor Business Unit
Carl-Benz-Str. 4, D-71154 Nufringen, Germany
Tel: (49) 7032-811-0/Fax: (49) 7032-811-199

OMRON ELECTRONICS LLC
One Commerce Drive Schaumburg,
IL 60173-5302 U.S.A.
Tel: (1) 847-843-7900/Fax: (1) 847-843-7787

OMRON ASIA PACIFIC PTE. LTD.
No. 438A Alexandra Road # 05-05/08 (Lobby 2),
Alexandra Technopark,
Singapore 119967
Tel: (65) 6835-3011/Fax: (65) 6835-2711

OMRON (CHINA) CO., LTD.
Room 2211, Bank of China Tower,
200 Yin Cheng Zhong Road,
PuDong New Area, Shanghai, 200120, China
Tel: (86) 21-5037-2222/Fax: (86) 21-5037-2200

Authorized Distributor:

© OMRON Corporation 2011 All Rights Reserved.
In the interest of product improvement,
specifications are subject to change without notice.

CSM_1_1_1211
Cat. No. E416-E1-01

Printed in Japan
1111(1111)